

PLEASE CHECK LOUVRE DIMENSIONS and ORIENTATION PRIOR TO ORDER

Type **F30B Ducog grille**



Application: **24mm Glaze-in**

Blade: **Z Profile P2 Bird pierced**

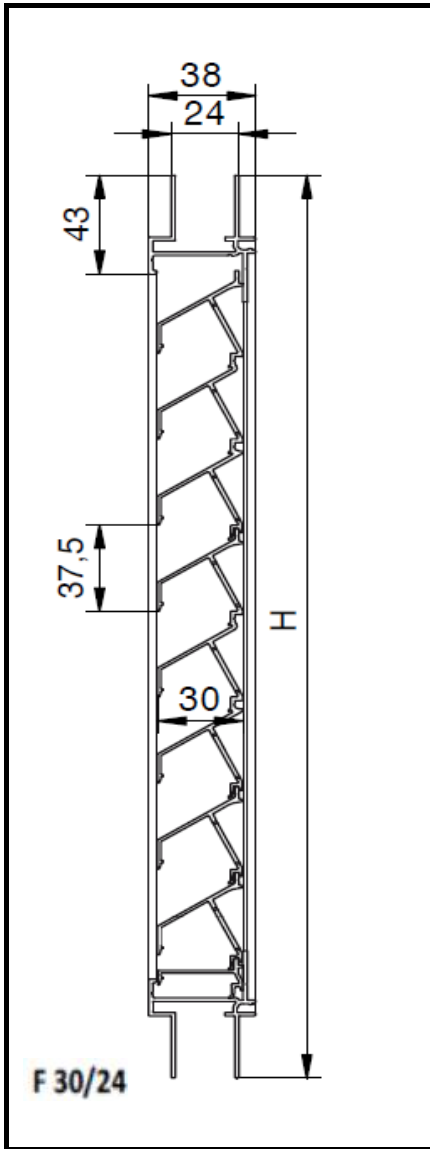

Specification:

All profiles are aluminium extrusions manufactured to BVQI Certificate No.57832, A1 Mg Si 0.05, 1.50mm profile thickness.

Frame Profile:

Equal leg outer frame to suit "glaze in" applications

Blade:

High security 'chevron form' interlocking aluminium extrusions

Blade Pitch: 37.5mm

Bird Meshing:

Integrated bird screen within punched louvre blades

Punched blade at "C"

Water Repellent Efficiency:

See pp46-48, Duco Architectural Grilles brochure

Indicative airflow:

Airflow: 2.53 L/s/dm² at 1 Pa (13 m³ /h/dm² at 2 Pa)

48% physical free area (note: B/C)

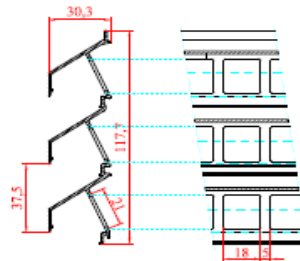
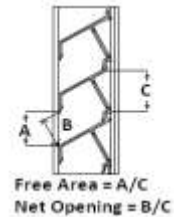

DGS Triple blade
30Z P2

Cross section of the 30Z P2 blade with 18mm x 21mm bird punchings at "C"
- believed to be BS6644 compliant.
2.3 mm stainless steel insect mesh or 6 mm bird mesh can be fitted on request.

Finish availability:

- Mill finish
- Polyester Powder Coating (Syntha Pulvin)
carried out to BS 6496
 - Standard RAL. (40-60 um)
 - MATT 30%(+/- 5%)
 - SATIN 60%(+/- 5%)
 - GLOSS 80%(+/-5%)
 - Premium RAL.
- Anodised, SAA15 Anodised, SAA25

Manufacturing tolerance = +/- 5mm on supplied dimensions



Timothy's Bridge Road
Stratford upon Avon
Warwickshire, CV37 9NQ
Tel: 01789 414044
Fax: 01789 415273
email: info@buildingprofiles.co.uk
www.buildingprofiles.co.uk